

Eclipse RatioAir Burners

Model RA0500

Version 2

Parameter		Specifications		
		Packaged Blower Nominal (50Hz and 60Hz)		
Maximum Input, BTU/hr (kW) ^{1,2}	Chamber Pressure "w.c. (mbar)	Straight Combustor	Medium Velocity Combustor	High Velocity Combustor
	-2.0 (-5,0)	6,160,000 (1805)	5,796,000 (1698)	5,440,000 (1594)
	-1.0 (-2,5)	5,900,000 (1729)	5,563,000 (1630)	5,288,000 (1549)
	0.0 (0,0)	5,500,000 (1612)	5,300,000 (1553)	5,100,000 (1494)
	1.0 (2,5)	5,240,000 (1535)	5,065,000 (1484)	4,970,000 (1456)
	2.0 (5,0)	5,030,000 (1474)	4,797,000 (1406)	4,804,000 (1408)
Minimum Input, BTU/hr (kW) <i>Lower inputs may be achieved. Contact factory.</i>		100,000 (29)	100,000 (29)	100,000 (29)
Main Gas Inlet Pressure, "w.c. (mbar)³ <i>Fuel pressure at ratio regulator inlet.</i>	Maximum	55 (137)	55 (137)	55 (137)
	Minimum	15 (37)	15 (37)	20 (50)
High Fire Flame Length, inches (mm) <i>Measured from the outlet end of the combustor.</i>		100 (2540)	97 (2464)	75 (1905)
Maximum Flame Velocity, ft/s (m/s) <i>Approximately 15% excess air at maximum input.</i>		-	250 (75)	500 (150)
Maximum Application Temperature, °F (°C)	Alloy Combustor	1500 (820)	1750 (955)	1750 (955)
	Block & Holder	1900 (1040)	2800 (1540)	2800 (1540)
Flame Detection		UV scanner only		
Blower Motor Power, Hp	60 Hz	10" w.c. @ 66,000 scfh, 3 hp	10" w.c. @ 66,000 scfh, 3 hp	15" w.c. @ 66,000 scfh, 5 hp
	50 Hz	10" w.c. @ 66,000 scfh, 2.2 kW	10" w.c. @ 66,000 scfh, 2.2 kW	15" w.c. @ 66,000 scfh, 4 kW
Weight, lbs (kg)⁵	Alloy Combustor	509 (231)		
	Block and Holder	686 (311)		
Fuel <i>For any other mixed gas, contact Eclipse.</i>		Natural Gas ⁴		
Approvals				

¹ Maximum inputs for packaged blower versions are given for the standard combustion air blower without an inlet air filter.

² Blower motor service factors greater than 1.0 may be required when firing into negative chamber pressure applications. For specific application questions, contact Eclipse.

³ For proper performance, this pressure must be kept constant across the burner operating range.

⁴ See Design Guide 111 for more information about typical fuel composition and properties.

⁵ All weights are approximate.

- All inputs based upon gross calorific values and standard conditions: 1 atmosphere, 70°F (21°C).
- Blower motor service factors greater than 1.0 may be required when firing into negative chamber pressure applications. For specific application questions, contact Eclipse.
- Eclipse reserves the right to change the construction and/or configuration of our products at any time without being obliged to adjust earlier supplies accordingly.
- All information is based on laboratory testing in neutral (0.0" w.c.) chamber with standard combustor design. Different chamber conditions may affect the data.

Control & Operation Curve

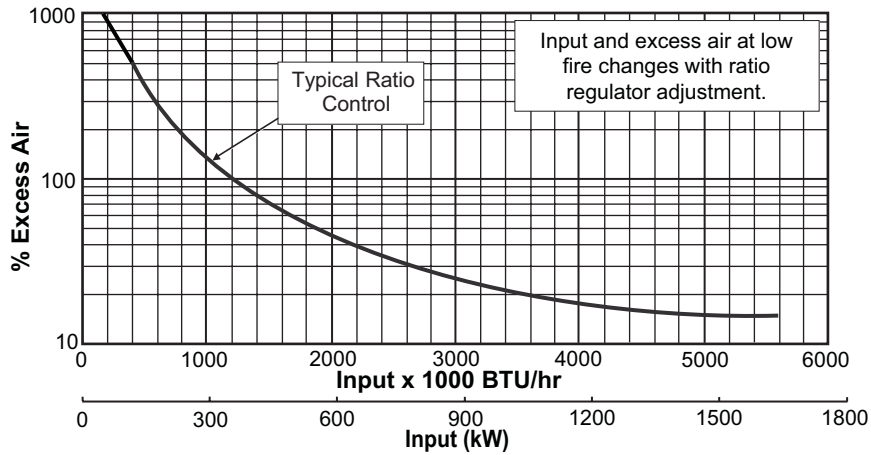

Straight Combustor Specifications

NO_x Emission Data

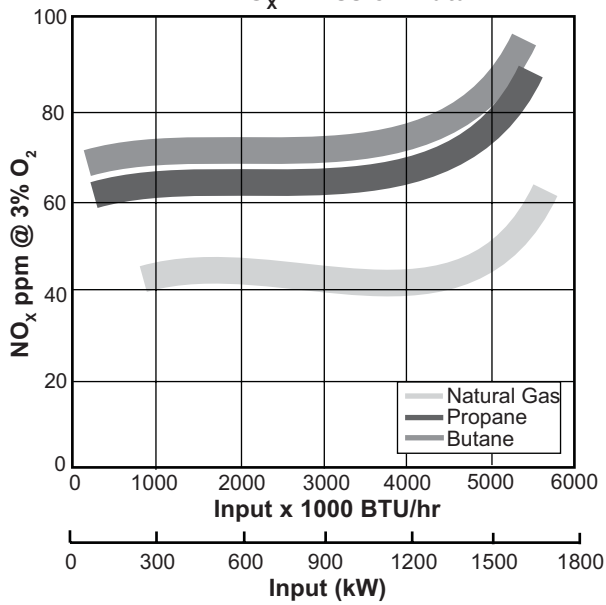

NO_x emission data is given for:

- Ambient combustion air ~70°F (20°C)
- Minimal process air velocity
- ppm volume dry at 3% O₂
- Neutral chamber pressure

Emissions are influenced by:

- Chamber conditions
- Fuel type
- Firing rate
- Ratio regulator adjustment
- Combustion air temperature

CO emission is largely influenced by chamber conditions. Contact your local Eclipse representative for an estimate of CO emission on your application.

Fuel Orifice Δp vs. Input Δp Measured Between Taps B & D

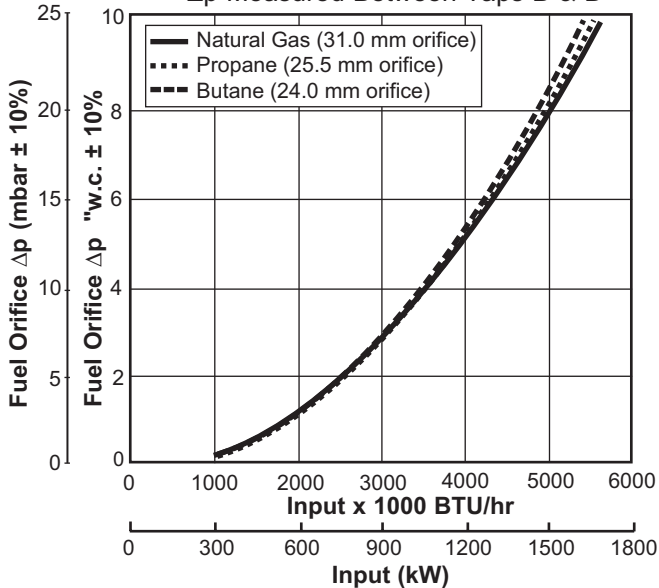

Air Δp vs. Input

(Measured Between Tap C & the Chamber with the Burner Firing)

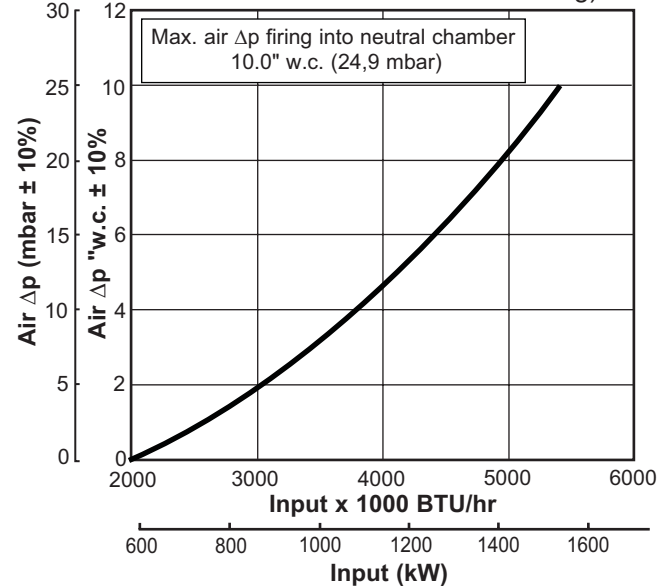

Medium Velocity Combustor Specifications

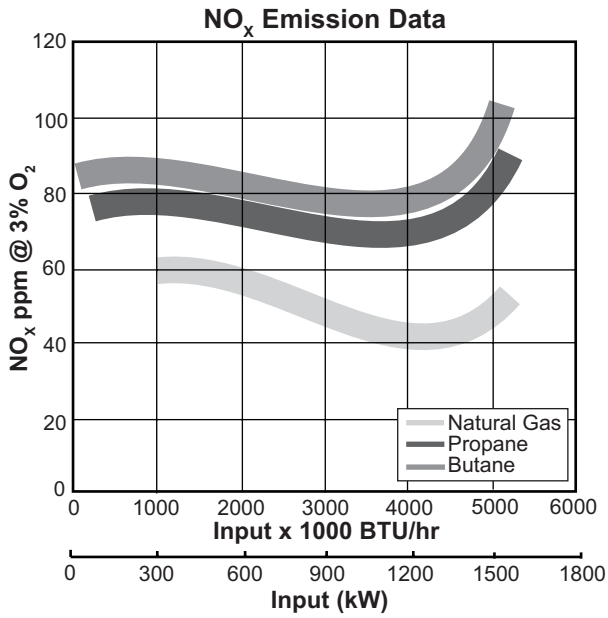

NO_x emission data is given for:

- Ambient combustion air ~70°F (20°C)
- Minimal process air velocity
- ppm volume dry at 3% O₂
- Neutral chamber pressure

Emissions are influenced by:

- Chamber conditions
- Fuel type
- Firing rate
- Ratio regulator adjustment
- Combustion air temperature

CO emission is largely influenced by chamber conditions. Contact your local Eclipse representative for an estimate of CO emission on your application.

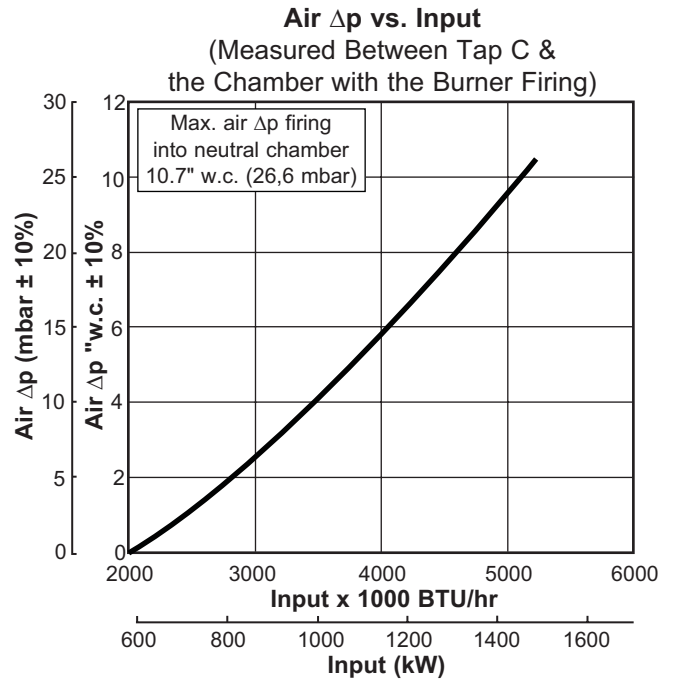
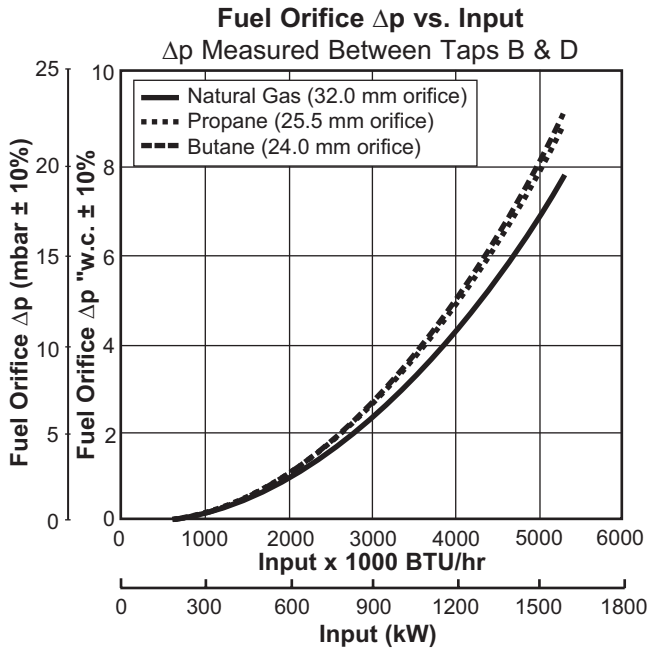

High Velocity Combustor Specifications

NO_x Emission Data

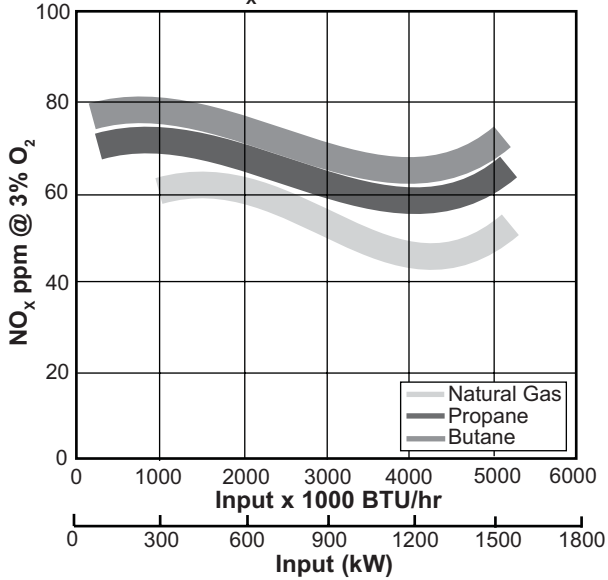

NO_x emission data is given for:

- Ambient combustion air ~70°F (20°C)
- Minimal process air velocity
- ppm volume dry at 3% O₂
- Neutral chamber pressure

Emissions are influenced by:

- Chamber conditions
- Fuel type
- Firing rate
- Ratio regulator adjustment
- Combustion air temperature

CO emission is largely influenced by chamber conditions. Contact your local Eclipse representative for an estimate of CO emission on your application.

Fuel Orifice Δp vs. Input

Δp Measured Between Taps B & D

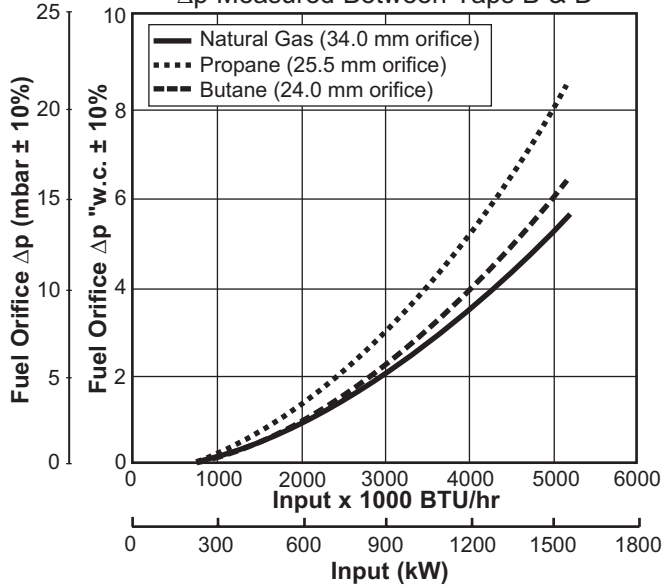

Air Δp vs. Input

(Measured Between Tap C & the Chamber with the Burner Firing)

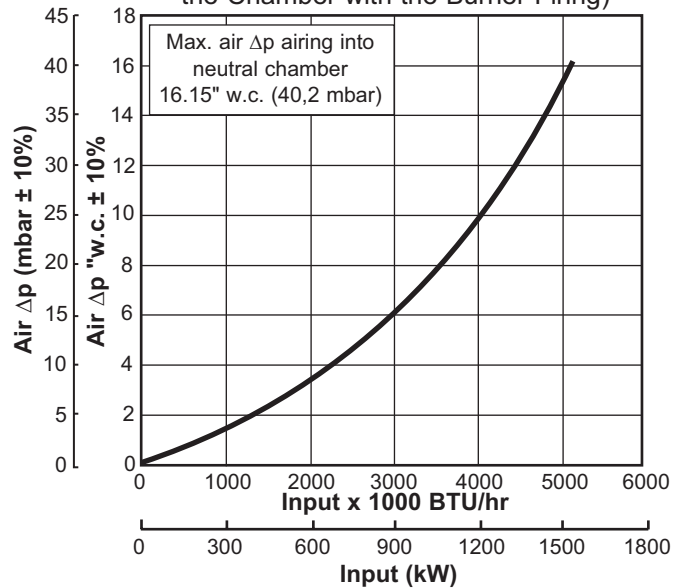

Dimensions in mm (inches)

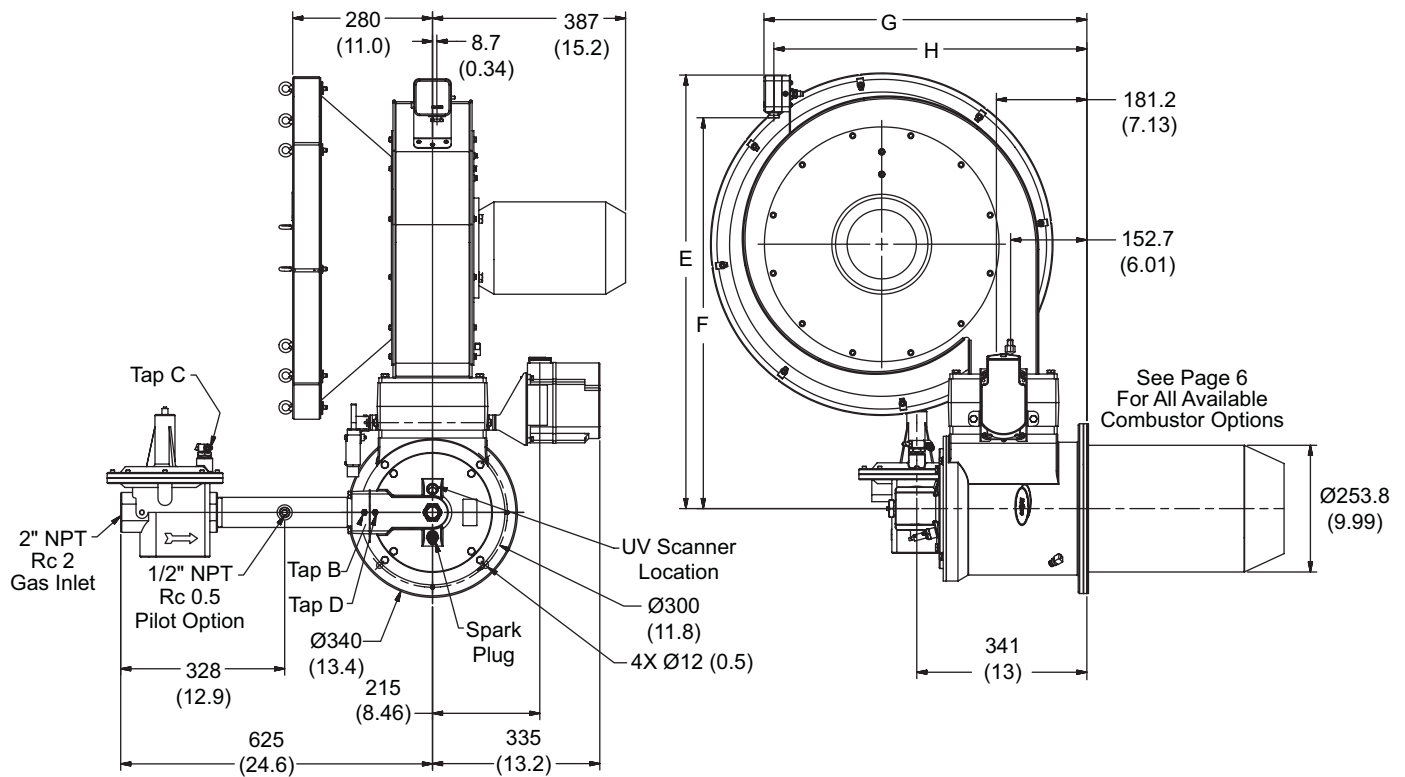

	Combustor Type	Filter Type	Dimensions mm (inches)			
			E	F	G	H
60 Hz Blower	Straight	Round	850 (33.5)	936 (36.9)	613 (24.1)	593 (23.3)
	Medium Velocity	Round	850 (33.5)	936 (36.9)	613 (24.1)	593 (23.3)
	High Velocity	Round	869 (34.2)	955 (37.6)	647 (25.5)	627 (24.7)
	Straight	Automotive*	850 (33.5)	936 (36.9)	613 (24.1)	593 (23.3)
	Medium Velocity	Automotive*	850 (33.5)	936 (36.9)	613 (24.1)	593 (23.3)
	High Velocity	Automotive*	869 (34.2)	955 (37.6)	647 (25.5)	627 (24.7)
50 Hz Blower	Straight & Medium Velocity	Round	869 (34.2)	955 (37.6)	647 (25.5)	627 (24.7)
	High Velocity	Round	883 (34.8)	969 (38.1)	679 (26.7)	659 (25.9)

* Round filters are illustrated above. Automotive filters are 500 x 500 (20 x 20).

Burner Configuration & Piping Arrangement

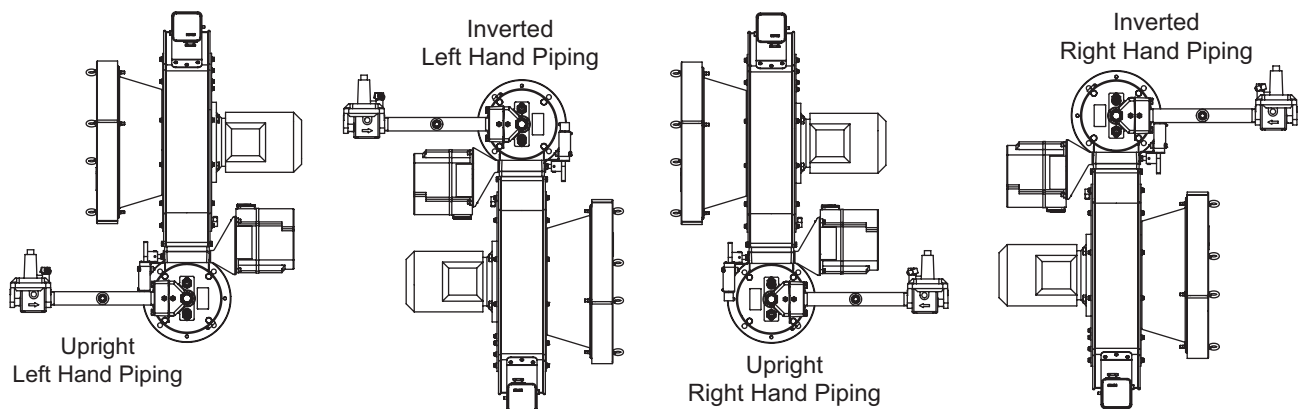

Combustor Options

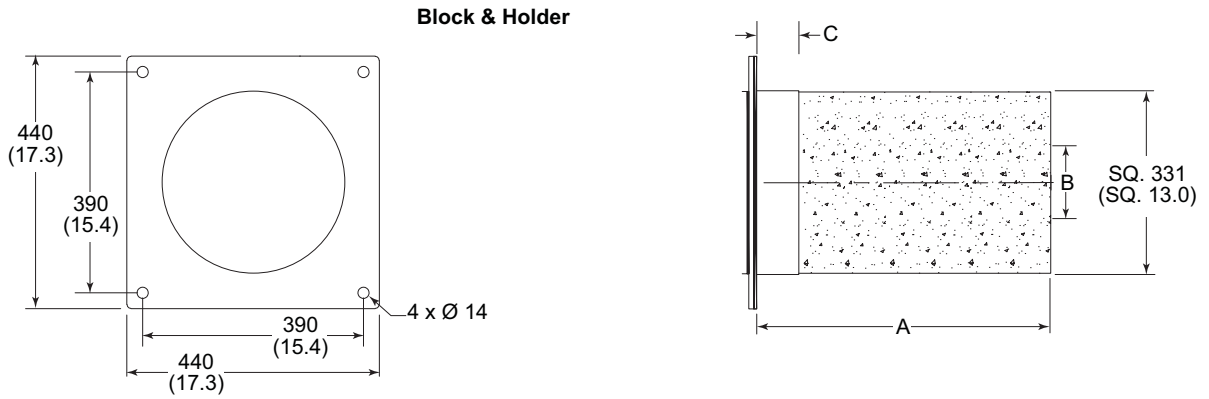
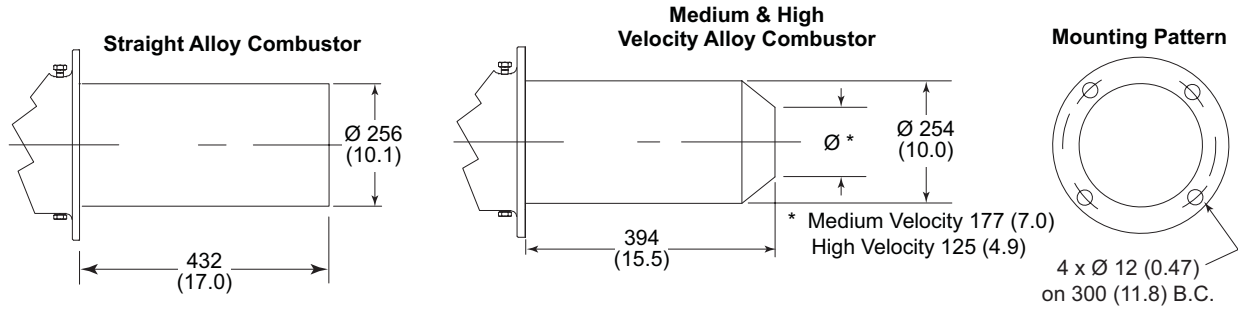

Block & Holder Option	Dimensions mm (inches)		
	A	B	C
Straight	342 (13.5)	249 (9.8)	317 (12.5)
Medium Velocity	394 (15.5)	177 (7.0)	50 (2.0)
High Velocity	394 (15.5)	125 (4.9)	50 (2.0)



Offered By:

Power Equipment Company
2011 Williamsburg Road
Richmond, Virginia 23231
Phone (804) 236-3800
Fax (804) 236-3882

www.peconet.com